

Installation and Operation Instructions

Onefinity Eazy-Z Tool Setter

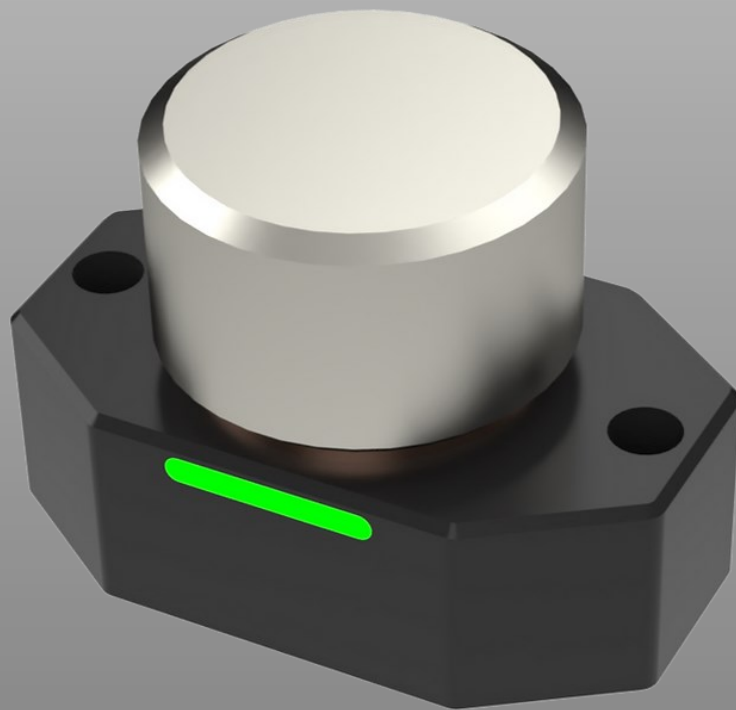

General Notes	3
Safety Rules	4-9
Description	10
Tool Setter Dimensions	11
Difference between Tool Setter and XYZ Probe	12
Tool Setter Mounting: QCW	13
Tool Setter Mounting: Table	14
Connecting your Tool Setter	15
Power On and Set-up	16
Set-up and F1 Screen	17
F2 Setting and Run	18
Onefinity Warranty Policy	19-20
Notes	21
Contact Us	22

This manual serves to familiarize you with your Onefinity CNC machine and provide all necessary information required to operate the machine safely and professionally.

This manual is applicable for the Onefinity Elite Foreman, Journeyman and Woodworker hereafter referred to as Onefinity or Onefinity Elite.

Please completely read this manual before the first commissioning of your machine. In order to minimize the risks of injury and/or material damages, please only commission the machine and the corresponding control when you are sure that you have completely understood these instructions!

Please contact us for any further questions. Please find our contact info on page 36 of these instructions.

Please always keep these instructions nearby the machine. You should always have them readily available when you want to look up something.

Please only use this machine according to its intended use.

We cannot be held liable for persons or material damages which are caused by using the machine other than the intended use, handling which does not comply with the common use of a CNC machine or if safety regulations are not obeyed

In case of improper maintenance (**refer to pages 40-41**) and/or wrong operation of the individual components your warranty claims are omitted.

We reserve the right to perform future technical enhancements on the machine and its components.

General Instructions:

These operating instructions explain the Onefinity and the correct handling of the CNC system. Please read these operating instructions and accompanying documents in their entirety before commissioning of the system in order to become familiar with the characteristics and the operation of the product. The improper operation of the CNC gantry milling system can lead to damage to the product and property and can cause serious injuries, electric shock and / or fire. It is imperative to adhere to the safety instructions listed in these operating instructions at all times. Should you have any questions or concerns prior to initial use of the CNC system or the need for further information, do not hesitate to contact us prior to the commissioning of the CNC system.

Safety Instructions and Protective Measures:

(General Safety Warnings for the Use of Power Tools)

Work Area Safety

NOTICE: Keep work area clean and well lit. Cluttered or dark areas invite accidents.



Caution: Do not operate the power tool in explosive atmospheres, such as in the presence of flammable liquids, gases or dust. Power tools create sparks which may ignite the dust or fumes.

NOTICE: Keep children and bystanders at a distance while operating a power tool. Distractions can cause you to lose control and can result in accidents.



Caution: Operate the Onefinity only in interior spaces on a solid, horizontal table or workbench.

Electrical Safety:



Warning: Power tool plugs must match the outlet. Never modify the plug in any way. Do not use any adapter plugs with grounded power tools. Unmodified plugs and matching outlets will reduce the risk of electric defects and malfunctions.



Warning: Do not expose power tools to moisture. The power tool is only suitable for indoor use. Water entering a laser tool will increase the risk of electric shocks.

Personal Safety:



Caution: Stay alert, watch what you are doing and use common sense when operating a power tool. Do not use a power tool while you are tired and/or under the influence of drugs, alcohol or medication. A moment of inattention while operating a power tool may result in serious personal injury.

NOTICE : All persons who operate the power tool must have read and fully understood all relevant safety and operating instructions. Misunderstanding may result in personal injury.



Caution: Use personal protective equipment. Always wear eye protection. Protective equipment, such as a suitable dust mask or ear protection, reduces the risk of injuries.

NOTICE: Dress properly. Do not wear loose clothing or jewelry. Pin your hair above your shoulders so that it cannot get caught in the Ball Screws and linear guides or moving parts.



Caution: This tool is controlled by a computer. During operation, it cannot be controlled directly. Lack of caution or expertise as well as program errors can lead to unexpected movements.



Caution: Do not touch the insertion tools or motors as they can heat up significantly during operation.



Caution: Never place any parts of the tool or accessories in the mouth as this can lead to serious injuries.

Protective Measures:

The Onefinity has been constructed for advanced users and is only to be operated by technically skilled persons above the age of 16. The CNC gantry milling system as well as associated tools, small parts and electrical components are to be stored outside the reach of children. The operator is solely responsible for understanding and reading the machine user guide and all relevant operating instructions in their entirety. These documents should always be stored in immediate vicinity of the machine. The manufacturer's instructions concerning the CNC machine and the tools, such as the milling spindle, are to be adhered to. The CNC gantry milling system is only to be used in a technically perfect condition which is to be ensured prior to each operation. The emergency switch as well as, if applicable, additional safety devices, always need to be easily accessible and fully functional. The use of liquids with the machine, such as the application of a coolant pump, is prohibited as it can damage the electronics. The use of lubrication systems is allowed. Please take into consideration that in this case the MDF machine table is not used as its MDF panels can swell and, thus, be destroyed.

Safety Rules

Use of the Power Tool:



Caution: Do not alter or misuse the tool. Any alteration or modification is a misuse and may result in serious personal injury.



Caution: Disconnect the plug from the power source before you make any adjustments, change accessories, or store the tool. Such preventative safety measures reduce the risk of starting the power tool accidentally.



Caution: Store idle power tools out of the reach of children and do not allow persons unfamiliar with the laser tool or these instructions to operate the power tool. Power tools are dangerous in the hands of untrained users.

NOTICE: Use the power tools, accessories etc. in accordance with these instructions, taking into account the working conditions and the work to be performed. Use of the power tool for operations different from those intended could result in a hazardous situation with high probability of superficial injury.

NOTICE: Do not reach into the area of the rotating insertion tools. The proximity of the rotating tools to your hand may not always be obvious.

NOTICE: Never use dull or damaged insertion tools. Sharp bits must be handled with care. Damaged bits can snap during use. Dull bits require more force to cut the tool, possibly causing the bit to break.

NOTICE: The speed and feed of the bit when carving, routing or cutting is very important. Always observe the recommended speed and feed for the particular bit.



Caution: If the workpiece or bit becomes jammed or bogged down, turn the power tool "OFF" by the switch. Wait for all moving parts to stop and unplug the tool, then free the jammed material. If the switch to the tool is left "ON", the tool could restart unexpectedly causing serious personal injury.

NOTICE: Do not leave a running tool unattended, turn power off. Only when tool comes to a complete stop and is disconnected from the mains it is safe.



Caution: Do not touch the bit or collet after use. After usage bit and collet are too hot to be touched with bare hands.

NOTICE: Do not allow familiarity gained from frequent use become commonplace. Always remember that a careless fraction of a second is sufficient to inflict severe injury.



Caution: When using the end mills, V-bits or cutters, always have the workpiece securely clamped. Never attempt to hold the workpiece with your hands while using any accessories. These tools can jam easily in the material, and can kickback, causing loss of control resulting in serious injury.

Care of the Power Tool:

NOTICE: Maintain the tools. Check for misalignment or binding of moving parts, breakage of parts and any other conditions that may affect the power tool's operation. If damaged, have the power tool repaired before use. Many accidents are caused by poorly maintained power tools.

Additional Safety Instructions



Caution: Depending on the application field of the machine (private or commercial), observe the applicable occupational safety and health, safety and accident prevention and environmental regulations.



Caution: Some dust created by cutting, milling or other construction activities contains chemicals known to cause cancer, birth defects or other reproductive harm. Some examples of these chemicals are: Lead from nonferrous metals with lead content, carbonate from carbon fiber, arsenic and chromium from chemically treated lumber. Your risk from exposures to these varies, depending on how often you perform this type of work. To reduce your exposure to these chemicals, work in a well ventilated area, and work with approved safety equipment, such as those dust masks that are specially designed to filter out microscopic particles.

Safely dispose of milling debris — recycle or safely dispose of milling debris and dust, keeping in mind flammability, (potential) spontaneous combustion, and chemical considerations. Even natural materials can have surprising implications for disposing of them, *e.g.*, walnut wood dust is alleopathic (inhibits plant growth) and an irritant to the skin and breathing tract and potentially poisonous to some animals in addition to the typical spontaneous combustion hazard which sawdust poses.

Personal Protective Equipment:

When working with the CNC gantry system, the operator has to wear at least the following personal protective equipment and has to be compliant with the below-mentioned safety aspects: - Safety goggles for protecting the eyes against flying chips etc. - Ear protection for protecting the ears against sound and noise. - No wearing of clothes which can get caught in the machine, such as ties, scarves, wide sleeves etc. Additionally, jewelry and especially long necklaces and rings are to be dispensed with. - Shoulder-length or longer hair is to be secured with a hairnet or a hat to prevent it from getting caught in the linear guides and / or rotating tools. Prior to all adjustments to the machine, its control or system-guided tools, such as the Milling Motor, the Drag Knife or the Hot Wire Cutter, the plug is to be disconnected from the power source. Never hold the workpiece to be processed with your hands. It is mandatory that the workpiece is securely fixed on the machine table. Otherwise there exists a high risk of injuries!

Emergency Stop Switch :

The emergency stop is located on the top of the Controller housing. In order to be able to intervene at all times, the emergency stop has to be positioned in a suitable place. The controller must be located so it can be reached from any possible operator position.





By pressing the emergency stop switch, the emergency stop is triggered. The control is interrupted. Additionally, the control software receives the signal to stop the operating process. The machine stops immediately.

ATTENTION! The emergency stop switch can only effect the stop of all components if these components are electronically connected with the emergency stop switch.

If you want to use a system-guided tool, such as a milling and drilling motor, that features a separate ON / OFF switch and that is NOT controlled via the PC, you have to make sure that it is expertly connected with the emergency stop switch. If you do not comply with these requirements, the system-guided tool will continue to run although you have activated the emergency stop switch leading to a high risk of personal injury and damage to property! If you have any questions, please do not hesitate to contact us!

Residual Risk:

Despite all safety precautions against the contact with rotating or hot tools and the protection from crushes, a residual risk remains due to a careless handling and automatic movements of the CNC system.

Symbol	Name	Explanation
	Symbol: Read manual	Alerts user to read manual BEFORE first commissioning
	Symbol: Wear ear protection	Alerts user to wear a hearing protector
	Symbol: Wear safety glasses	Alerts user to wear protective glasses
	General warning symbol	Alerts user to warning messages

Read the following carefully before operating the machine.

1. Keep the working area clean and ensure adequate lighting is available.
2. Do not wear loose clothing, gloves, bracelets, necklaces or ornaments.
3. Do wear face, eye, respiratory and body protection devices as indicated for the operation or environment.
4. Ensure that the power is disconnected from the machine before tools are serviced or any attachment is to be fitted or removed.
5. Never leave the machine with the power on.
6. Do not use dull, gummy or cracked cutting tools.
7. Ensure that the keys and adjusting wrenches have been removed and all the nuts and bolts are secured.
8. Hearing protection — ear plugs or muffs, for long jobs doubling up on ear plugs or muffs may be desirable. Hearing damage is cumulative and irreversible, so one should err on the side of caution
9. Use care when handling endmills, both to avoid being cut, and to avoid damaging them. Handling them with suitable gloves, or using a cloth to avoid contaminating them is recommended. Inspect them carefully before each use and ensure that they are securely held by the collet.
10. Never leave the machine running unattended/unsupervised.
11. Always inform someone before operating the machine and check in with them after successfully completing work.

Workspace:

The workspace needs to provide enough space around the Onefinity CNC for the machine to work comfortably and to be able to fully use its traveling paths. Additionally, a safe distance to possibly nearby positioned machines is to be maintained. The location of the machine as well as the workplace surrounding the machine has to be sufficiently illuminated.

As with all machinery, there are certain hazards involved with the operation and use of your machine. Using it with caution will considerably lessen the possibility of personal injury. However, if normal safety precautions are overlooked or ignored, personal injury to the operator may result. If you have any questions relating to the installation and operation, do not use the equipment until you have contacted your supplying distributor.

The Onefinity is a multifunctional CNC gantry milling system for the permanent and regular processing of wood, plastics and non-ferrous metals.

Thanks to the innovative design, how and where you carve is limitless! Feel like carving an intricate inlay into your dining table, no problem? Have a small shop where space is limited, Onefinity has been designed to be quickly dismantled and stored!

With Fast Travel Precision Ball Screws, gone are the stretchy belts and high maintenance Lead Screws found on similarly priced machines. Hardened Steel Hollow Linear Motion Shafts means no more plastic wheels that require frequent adjustment and a powerful CNC controller with built in CAM software and HD Touch Display allows for operation without a computer!

The machine has three axes which are offset by 90°. This way, it is possible to travel to any point within the working space. Each axis is equipped with up to two stepper motors and Infra-red homing. The stepper motors drive the movable axes elements via precision ball screws. The position of the axis is determined during the reference run (homing cycles), at the beginning of the job, with the aid of the homing. The machine table may consist of any solid flat surface big enough to mount the Rails and Controller. The Onefinity consists of the following, sometimes optional, components: - Onefinity Elite Foreman, Journeyman or Woodworker; - Onefinity MASSO electronic control unit, Power Supply Controller in a separate aluminum housing, Z-Slider, Wire harness and Hardware.

Eazy-Z Tool Setter Dimensions

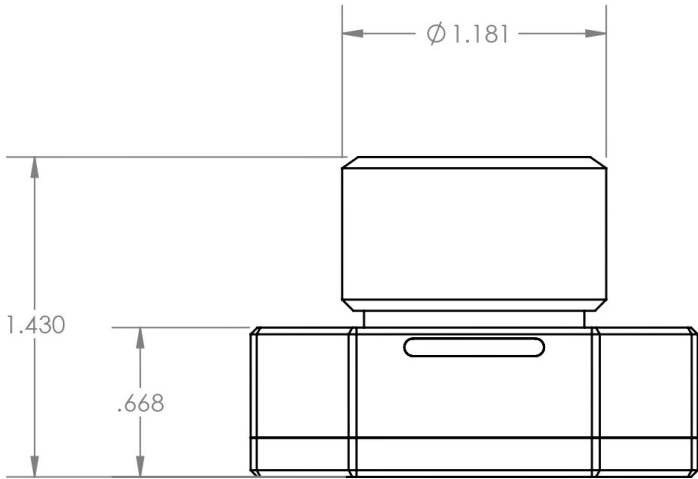
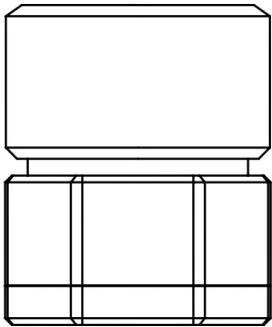
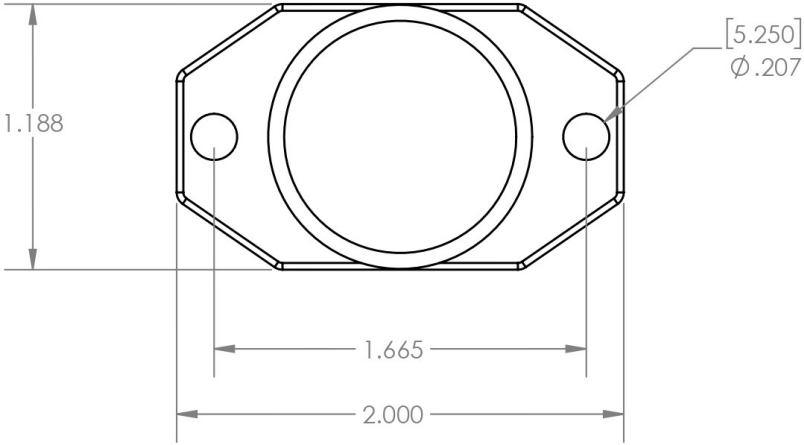
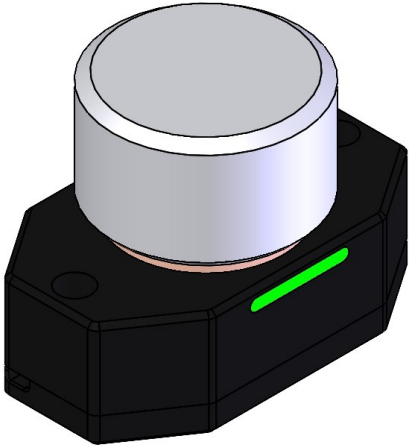

Understanding the differences between a tool setter and touch probe

Begin by understanding the differences between the Eazy Z Tool Setter and the XYZ Touch Probe:

EZ Auto Tool Zero: Automated process for setting Z offset above the material. Material must be loaded.

XYZ Touch Probe: Manually sets X, Y, and Z offsets. Determines material location relative to the home position.

Eazy Z Tool Setter

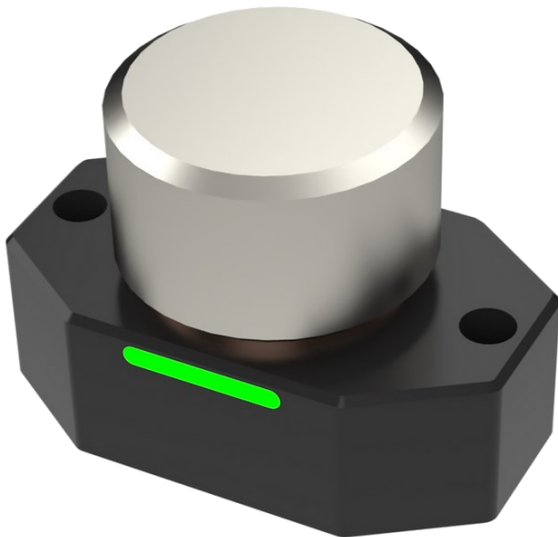

Touch Probe



Tool Setter Mounting: QCW Version

The following instructions detail how to install your Onefinity Elite CNC Machine. Please read these entire instructions carefully. If you have any problems or do not understand these instructions please contact us at support@onefinitycnc.com or 1-888 717 4242 for further assistance.

For step-by-step instructional videos and how-to's please visit our YouTube page at: <https://www.youtube.com/onefinitycnc>.

Note: It is highly recommended that you view all of our assembly videos prior to attempting to assemble your Onefinity machine. Our assembly videos can be found at: [youtube.com/onefinitycnc](https://www.youtube.com/onefinitycnc)

Mounting your Eazy-Z Tool Setter to your QCW:

Step 1: Mount the QCW Mount to your Tool Setter using the supplied bolts.

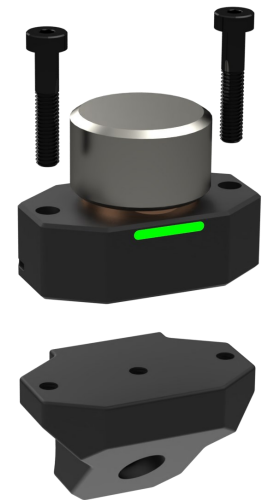

Step 2: Secure it using one of the bolts on the front tube. Remove the bolt, insert it through the tool setter QCW mount hole and reinstall into the tube of the QCW.



Tool Setter Mounting: One Table

If installing on the table top: Screw the Tool Setter directly to the table using the included screws.

Note: To ensure your Dust Shoe does not interfere with your Eazy-Z Tool Setter, fasten the Tool Setter onto your table not on top of your Waste Board.

Position of installation is up to the end user. There are many things to consider when positioning, including: tiling, if the endmill will reach, and maximizing the material positioning.



Depending on your positioning, you may want to place the wire out the opposite side of the tool setter. To do so, use a 2mm hex key to remove the bolts holding the Bottom Plate to the body of the tool setter. Position the wire so it's on the other side of the Tool Setter body. Rotate the Bottom Plate so the wire cut out is located on the new wire side. Reattach the Bottom Plate ensuring the wires are carefully routed out the side correctly.

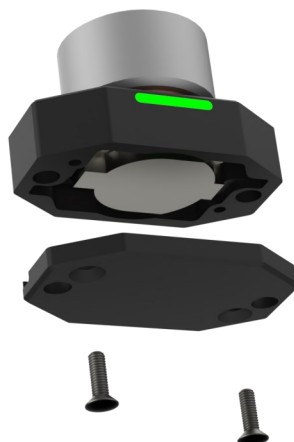

Connecting your Eazy Z Tool Setter

On the Back of the Masso controller, you will plug in the tool setter connection into the port labeled 'Tool Setter'. See below.

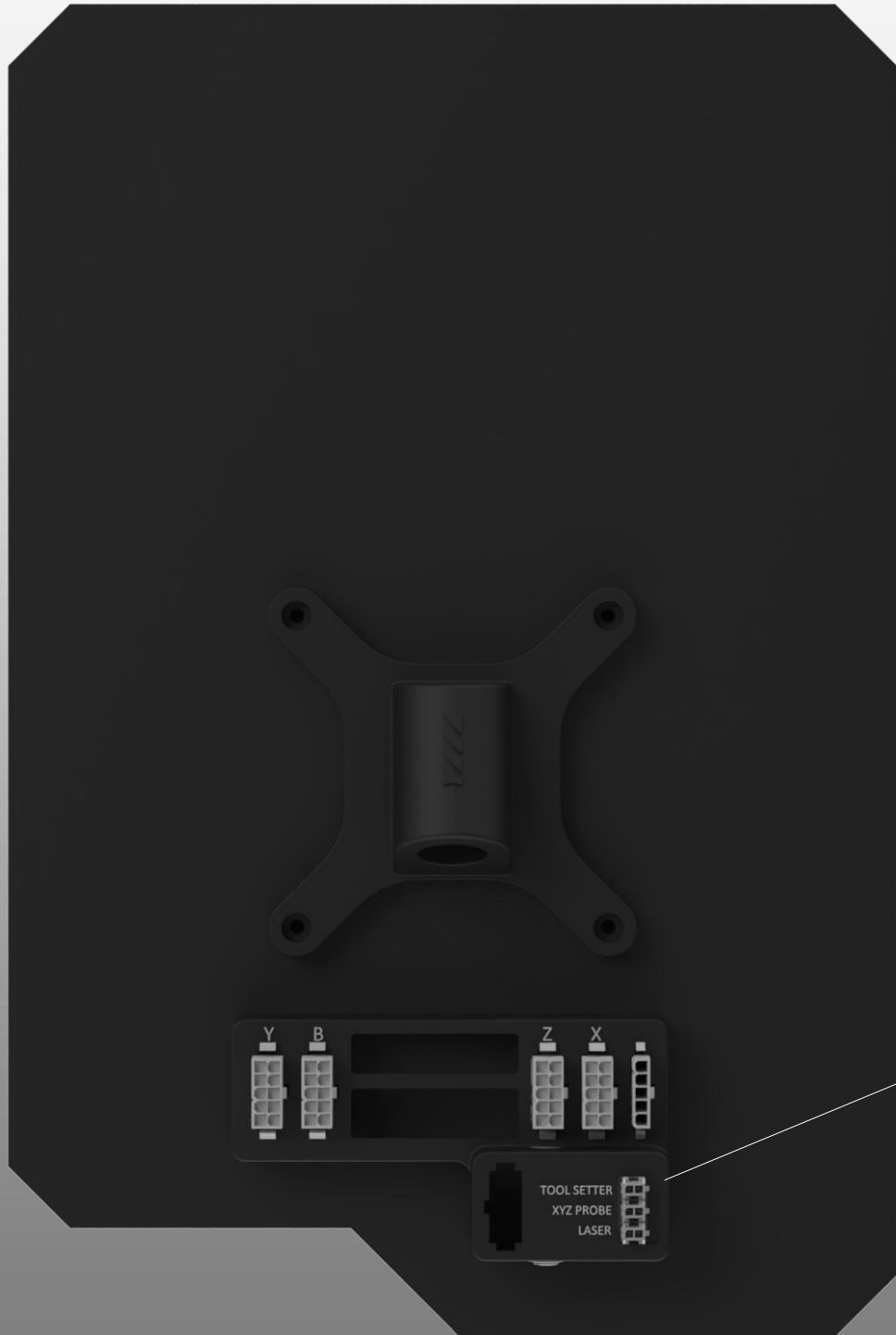

Tool Setter
Connector Port

Power On and Setup

Power On the Machine. Push in the estop and release the estop. Double tap the flashing yellow home button to home the machine. Place a bit into the router/spindle (a 1/8 endmill is ideal). Once an endmill is inserted, jog the machine so that the Z axis is directly over the tool setter. You want the centre of the bit to line up with the centre of the top circular plate of the tool setter.

Next we will note what the machine coordinates are under the 'machine' box on f2 screen in the upper right. With the bit centred above the tool setter, please write down the X and Y coordinates, as we need to input these laser.

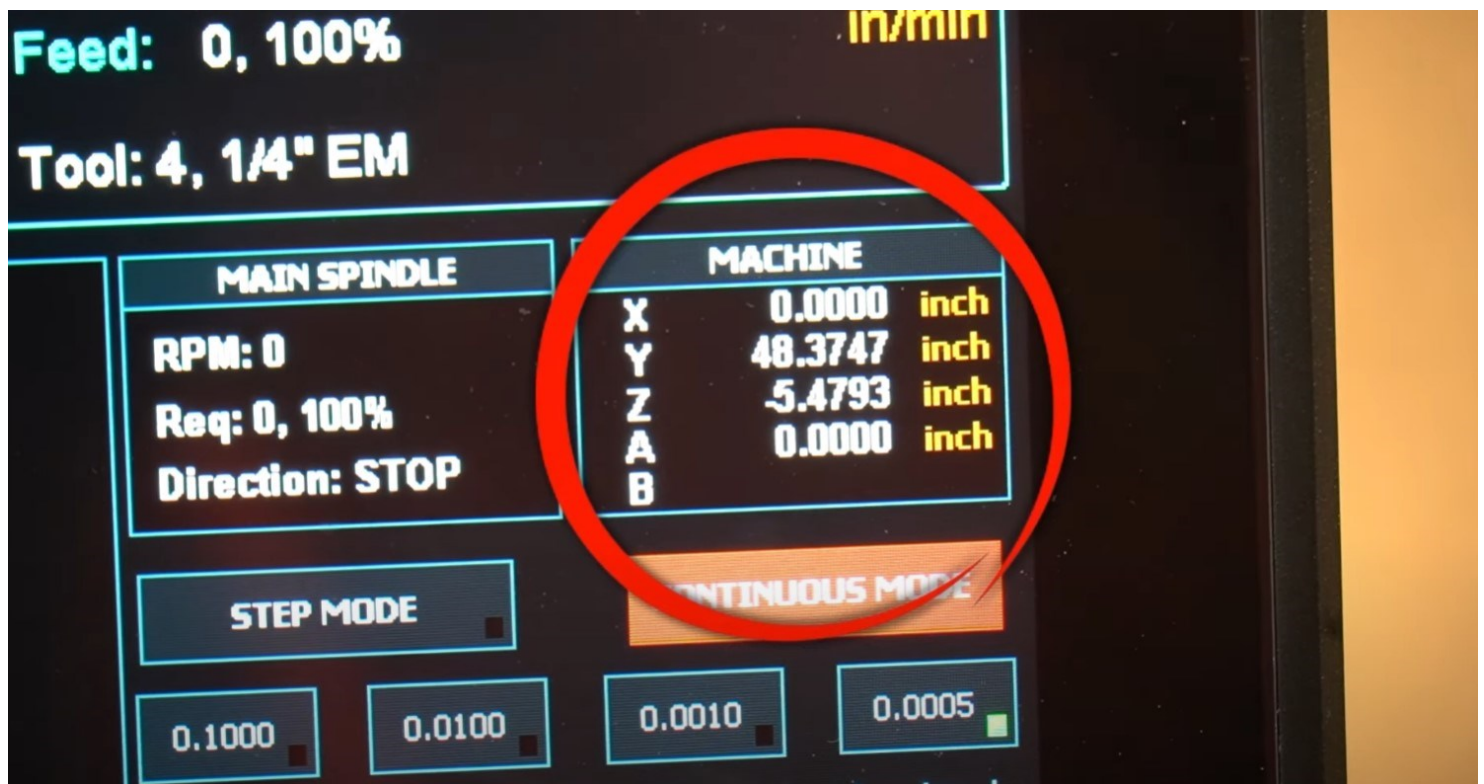

In our example picture our coordinates are:

X 0.0000

Y 48.3747

Setup and F1 Screen

Go to the F1 screen in the upper left hand side. Once there, in the left hand column, tap on the line that says 'Auto Tool Zero'.

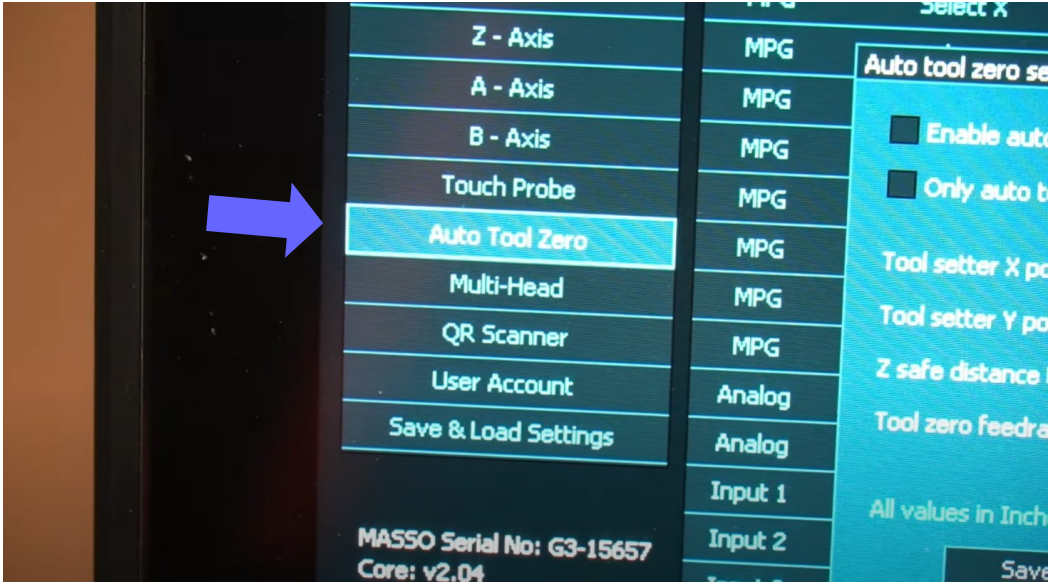

Once there, click the box next to 'enable auto tool zero' with a check mark to turn on the tool setter. Next, in "tool setter X position" we will use the number we wrote down earlier. (In our example case it is 0.00) Follow up with the tool setter Y position from what we wrote down earlier (in our example case it is 48.3747). Keep Z safe distance to tool setter at -1.00. Lastly, we'll change tool zero federate to 30 inches per minute. Once changed, click save.

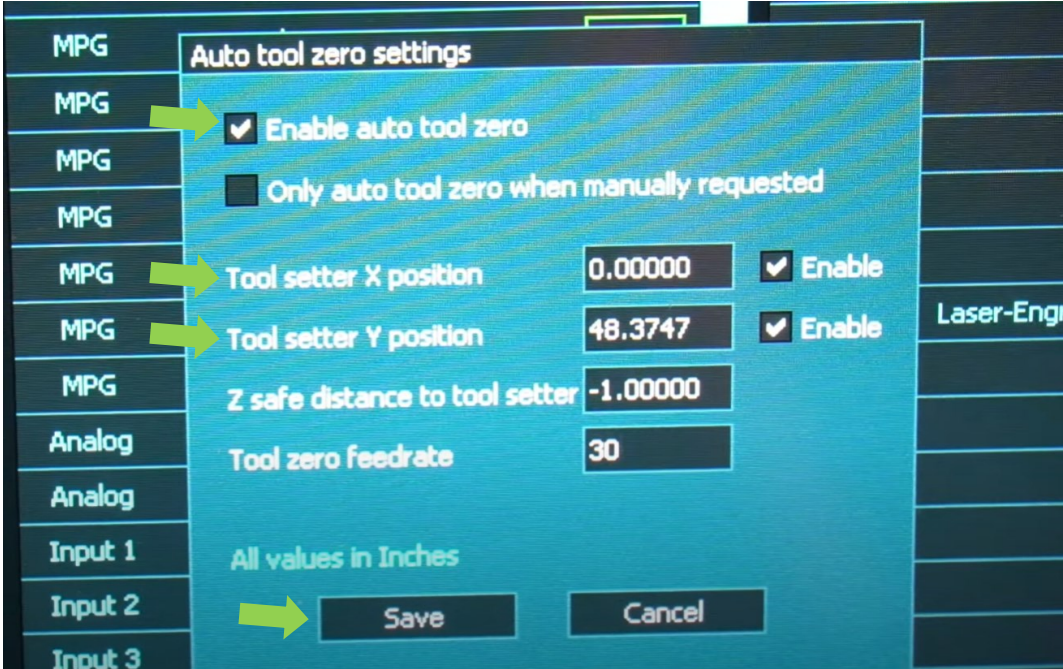

F2 Setting and Run

Once our settings are saved, we can go back to the F2 page and double click home. Once we have homed, the machine will go back to the tool setter after homing Z, X, and Y and manually set our tool offset.

We can now run multitool operations in one file. When running a file, you'll use the touch probe (or manual paper method) to set XY and Z Zero before running our first file. When the first bit has finished, the machine will stop the spindle and machine movement and ask to load the next tool (it's important to name and number these accordingly in your CAD/CAM software). Once you have changed the tool in the router/spindle, press the green cycle/start button and the machine will move over the tool setter, probe for the z offset, then continue the next carve. Rinse and repeat for all tools of the file and you're done!

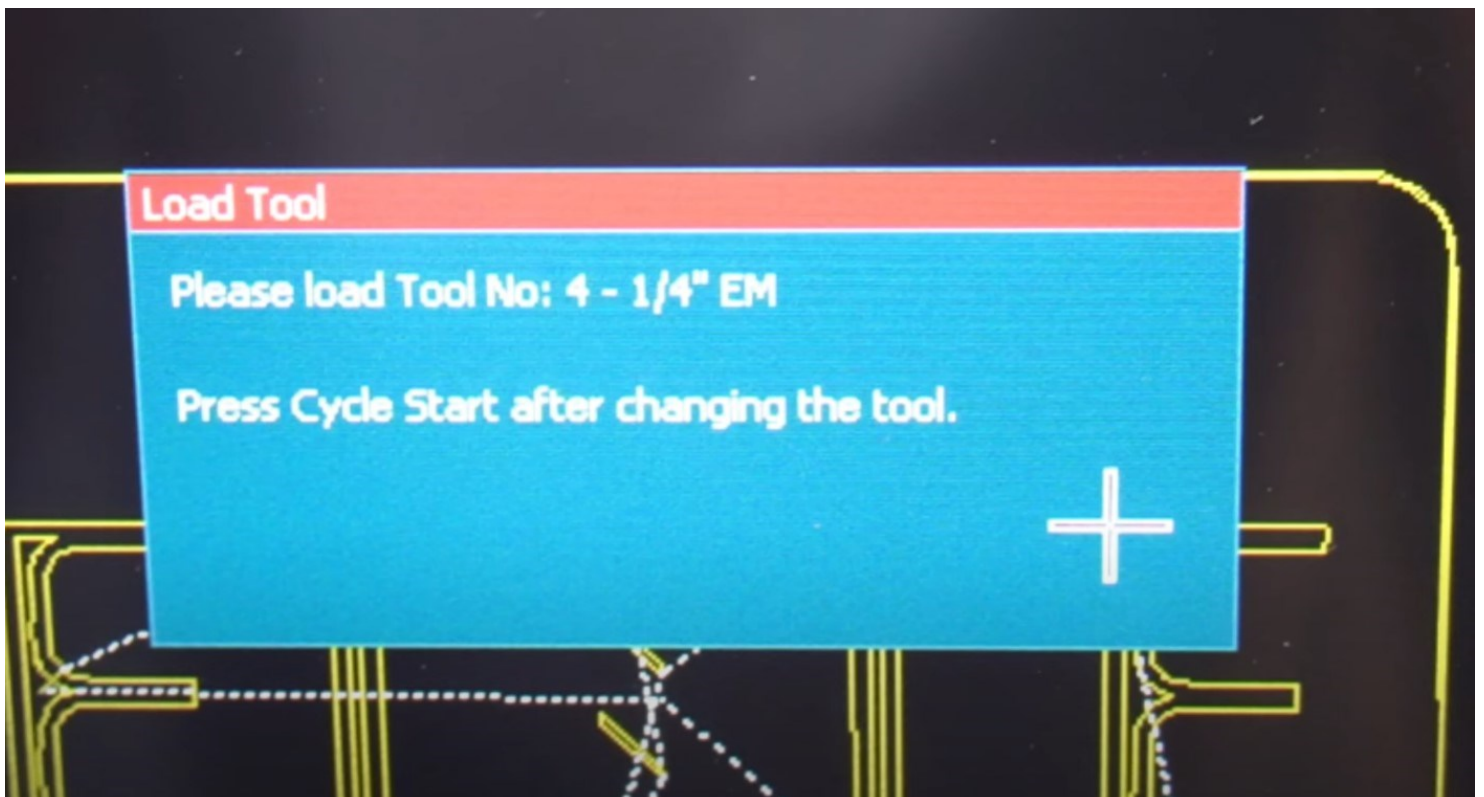

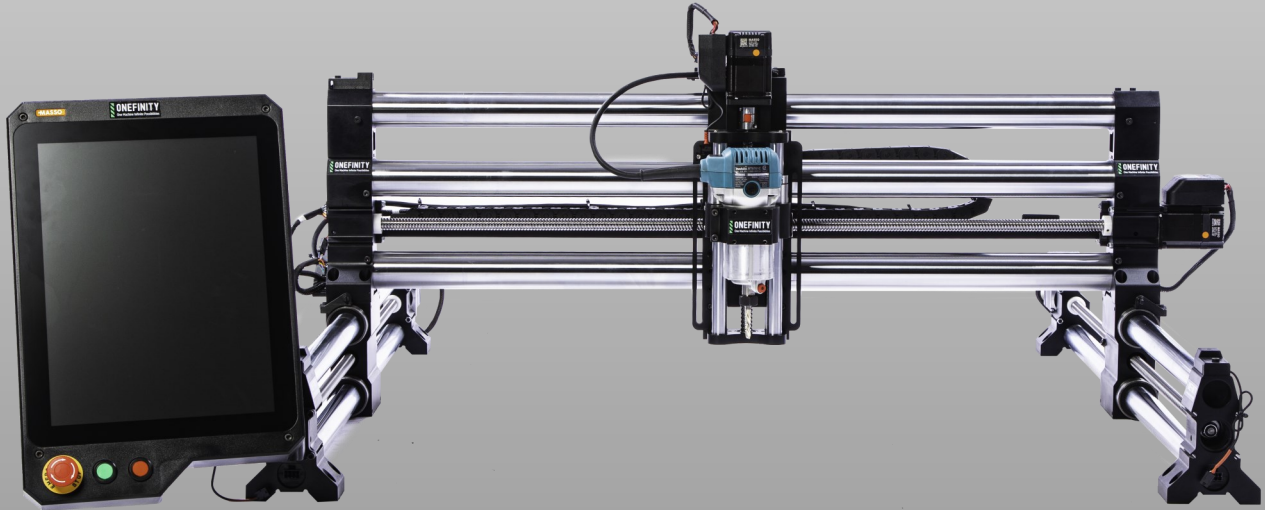

ONEFINITY ELITE 12-MONTH LIMITED WARRANTY

PLEASE SEE REVERSE SIDE FOR DETAILS

Limited warranty details

1. Kirbre Enterprises Inc. (“**Kirbre**”, “**us**”, “**we**”, “**our**”) warrants the Onefinity CNC machine (“**Onefinity CNC**”) to be free from defects in workmanship and materials for a period of twelve (12) months from the original shipment date when used in accordance with the Onefinity CNC Owner’s Manual. Warranty repairs may require you to install a replacement part provided by Kirbre or, at Kirbre’s discretion, require you to return the Onefinity CNC for warranty service. The Onefinity Limited Warranty is limited to the repair of the Onefinity CNC with new or refurbished parts for any defect in material or workmanship and when applicable, at our discretion, to the exchange of your warranted Onefinity CNC for a new or refurbished Onefinity CNC of equal or greater value.

2. **Verification and Return.** Such repair or replacement is subject to verification of the defect or malfunction and proof of purchase as confirmed by showing the Onefinity CNC model number on the original dated sales receipt. If we conclude shipping is necessary we will provide you with a shipping label. You are solely responsible for all shipping and handling fees as well as VAT, import duties, any applicable taxes, and other related fees (collectively “**Import Costs**”) you may be required to pay when shipping the Onefinity CNC to us, and we will not assume any responsibility for any payments relating thereto (including but not limited to brokerage fees, storage fees, etc.). You are solely responsible for any damage to the Onefinity CNC during shipping, so please ensure packaging of the Onefinity CNC follows the instructions provided in Section 3, “Returns”, of our Shipping and Returns Policy. Any additional costs incurred for transportation or removal of your Onefinity CNC are not covered by this Limited Warranty. For all valid warranty repairs, Onefinity will pay for return shipping to you excluding any Import Costs. If your machine does not qualify for warranty repair, then you will be required to pay for all shipping related costs to and from Kirbre including any Import Costs.

3. **WARRANTY LIMITATIONS.** This warranty does not cover repairs for:

- * Onefinity CNC used for commercial purposes or used in any manner for which the product was not intended, such as use in rental or contract trade
- * Onefinity CNC damaged as a result of incorrect or inadequate maintenance or care
- * Damages resulting from misuse, abuse, negligence, accidents or shipping damage
- * Damages that are the result of normal wear and tear
- * Damages incurred during transportation
- * Damages incurred during assembly or maintenance
- * Damages that are determined to be from repairs made by third parties not authorized by Kirbre

Without limiting the generality of the foregoing, this warranty will be void and no warranty coverage will be provided if you do any of the following:

install any firmware in the Onefinity CNC which is not specifically issued or authorized by Kirbre; make any change or modification to the electronics or computer components of the Onefinity CNC; attach any peripherals or accessories to the electronics or computer components of the Onefinity CNC that have not been specifically issued or authorized by Kirbre; use or attempt to use the Onefinity CNC and/or its electronics or computer components to control or move any device or object not specifically issued or authorized by Kirbre; or if the Onefinity CNC’s serial number has been removed or altered.

4. **Obtaining Service.** To obtain warranty service, first email Onefinity at support@onefinity.com and include your order number, contact info along with a brief explanation of the issue you are having. Once your email is received someone on our team will contact you by email to conduct a warranty diagnosis. You may be required to provide pictures and/or video of the claimed defect. If we cannot determine from the warranty diagnosis whether your Onefinity CNC qualifies for warranty repair we may require you to return the Onefinity CNC to Kirbre for further evaluation.

5. ACCEPTANCE OF THE EXCLUSIVE REPAIR AND REPLACEMENT REMEDIES DESCRIBED HEREIN IS A CONDITION OF THE CONTRACT FOR THE PURCHASE OF EVERY ONEFINITY CNC MACHINE. IF YOU DO NOT AGREE TO THIS CONDITION, YOU SHOULD NOT PURCHASE THE PRODUCT. IN NO EVENT SHALL KIRBRE, ITS DIRECTORS, OFFICERS, EMPLOYEES, AGENTS, CONSULTANTS, LICENSORS AND THIRD PARTY SUPPLIERS BE LIABLE FOR ANY INCIDENTAL, SPECIAL, CONSEQUENTIAL OR PUNITIVE DAMAGES, OR FOR ANY COSTS, ATTORNEY FEES, EXPENSES, LOSSES OR DELAYS ALLEGED TO BE AS A CONSEQUENCE OF ANY DAMAGE TO, FAILURE OF, OR DEFECT IN ANY PRODUCT INCLUDING, BUT NOT LIMITED TO, ANY CLAIMS FOR LOSS OF PROFITS. SOME JURISDICTIONS DO NOT ALLOW THE EXCLUSION OR LIMITATION OF INCIDENTAL OR CONSEQUENTIAL DAMAGES, SO THE FOREGOING LIMITATION OR EXCLUSION MAY NOT APPLY TO YOU. THIS WARRANTY IS EXCLUSIVE AND IN LIEU OF ALL OTHER EXPRESS WARRANTIES, WRITTEN OR ORAL. TO THE EXTENT PERMITTED BY LAW, KIRBRE DISCLAIMS ANY IMPLIED WARRANTIES, INCLUDING WITHOUT LIMITATION ANY IMPLIED WARRANTY OF MERCHANTABILITY OR FITNESS FOR A PARTICULAR USE OR PURPOSE; TO THE EXTENT SUCH DISCLAIMER IS NOT PERMITTED BY LAW, SUCH IMPLIED WARRANTIES ARE LIMITED TO THE DURATION OF THE APPLICABLE EXPRESS WARRANTY AS DESCRIBED ABOVE. SOME STATES AND PROVINCES DO NOT ALLOW LIMITATIONS ON HOW LONG AN IMPLIED WARRANTY LASTS, SO THE ABOVE LIMITATION MAY NOT APPLY TO YOU, THIS WARRANTY GIVES YOU SPECIFIC LEGAL RIGHTS, AND YOU MAY ALSO HAVE OTHER RIGHTS WHICH VARY FROM STATE TO STATE AND PROVINCE TO PROVINCE.



General Disclaimer:

While Onefinity has made every effort at the time of publication to ensure the accuracy of the information provided herein, product specifications, configurations, system/component/options availability are all subject to change without notice. Product design specifications and colours are subject to change without notice and may vary from those shown. Errors and omissions excepted. Images displayed are for illustration purposes only. The images are intended to help illustrate the product and its functions and are not indicative of actual relative differences.

www.onefinitycnc.com

Email: info@onefinitycnc.com or Call: 1 888 717 4242

CE



General Disclaimer:

While Onefinity has made every effort at the time of publication to ensure the accuracy of the information provided herein, product specifications, configurations, system/component/options availability are all subject to change without notice. Product design specifications and colours are subject to change without notice and may vary from those shown. Errors and omissions excepted. Images displayed are for illustration purposes only. The images are intended to help illustrate the product and its functions and are not indicative of actual relative differences.